

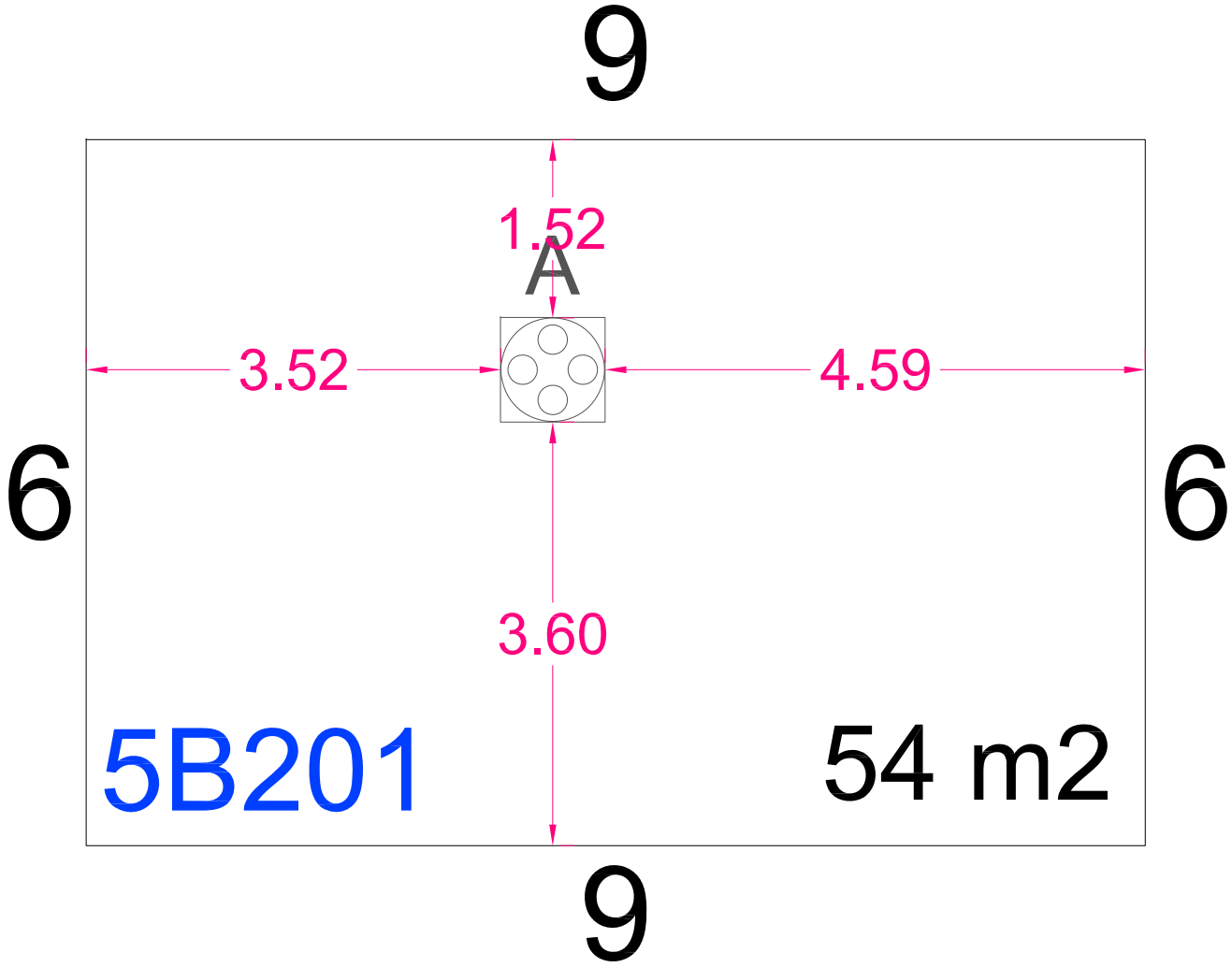









# Stand plan



**Legend:**

-  Service chest 90x90cm
-  Fire hose
-  Fire extinguisher

**Maximum Height**

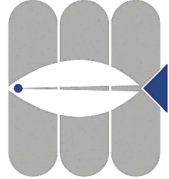
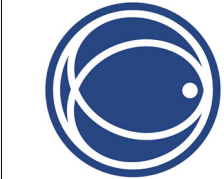

-  6m
-  5m (Under walkway projection + 25cm)
-  4.58m
-  4.55m
-  4m
-  2.5m



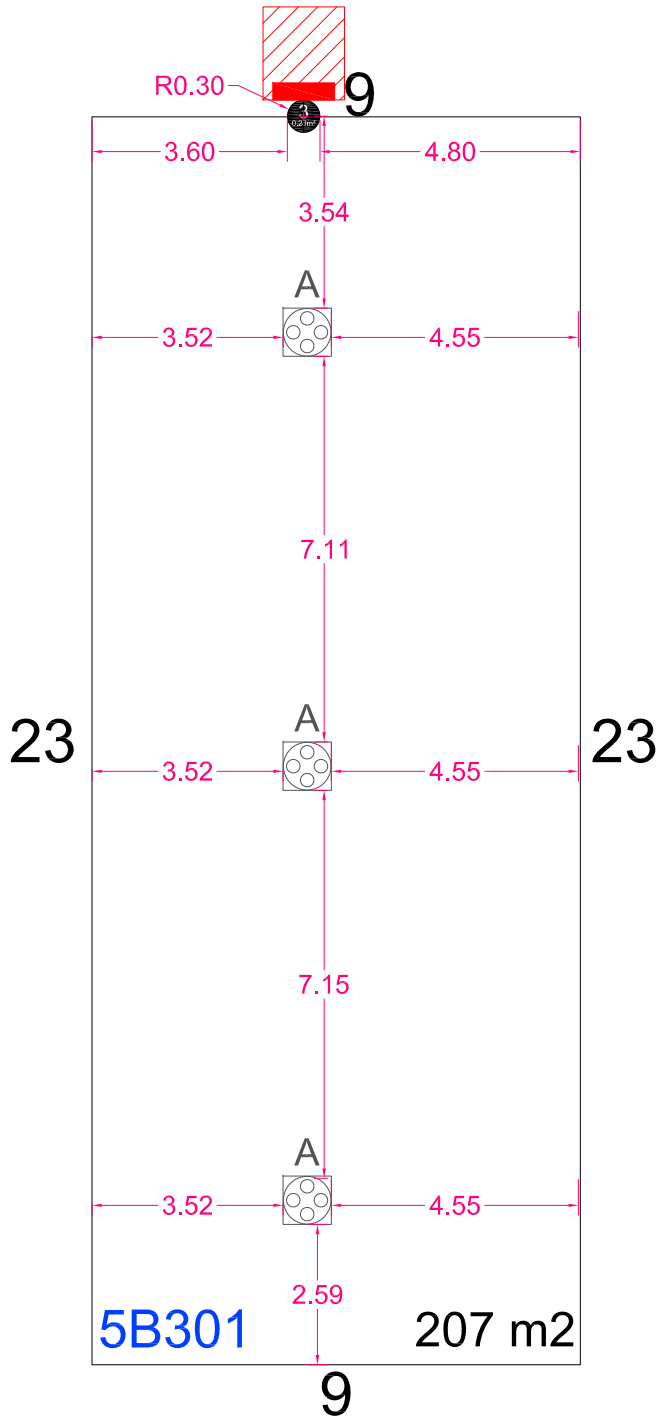





# Stand plan



**Legend:**

-  Service chest 90x90cm
-  Fire hose
-  Fire extinguisher

**Maximum Height**

-  6m
-  5m (Under walkway projection + 25cm)
-  4.58m
-  4.55m
-  4m
-  2.5m

# Stand plan

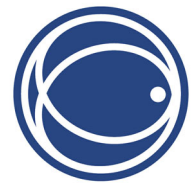
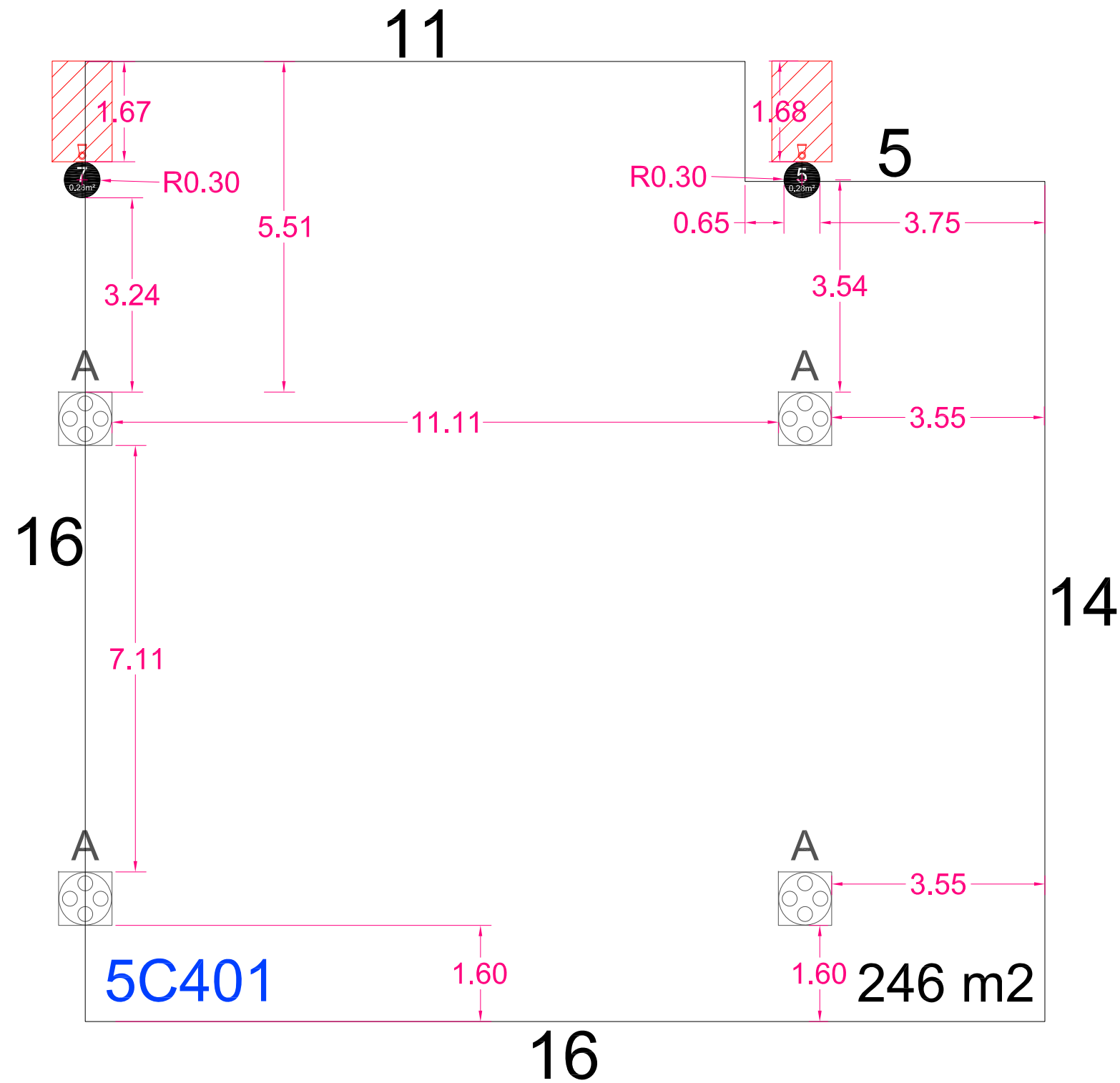

**Legend:**

- Service chest 90x90cm
- Fire hose
- Fire extinguisher

**Maximum Height**

- 6m
- 5m (Under walkway projection + 25cm)
- 4.58m
- 4.55m
- 4m
- 2.5m

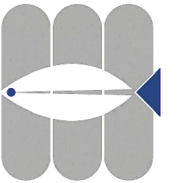

# Stand plan

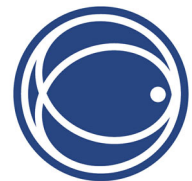
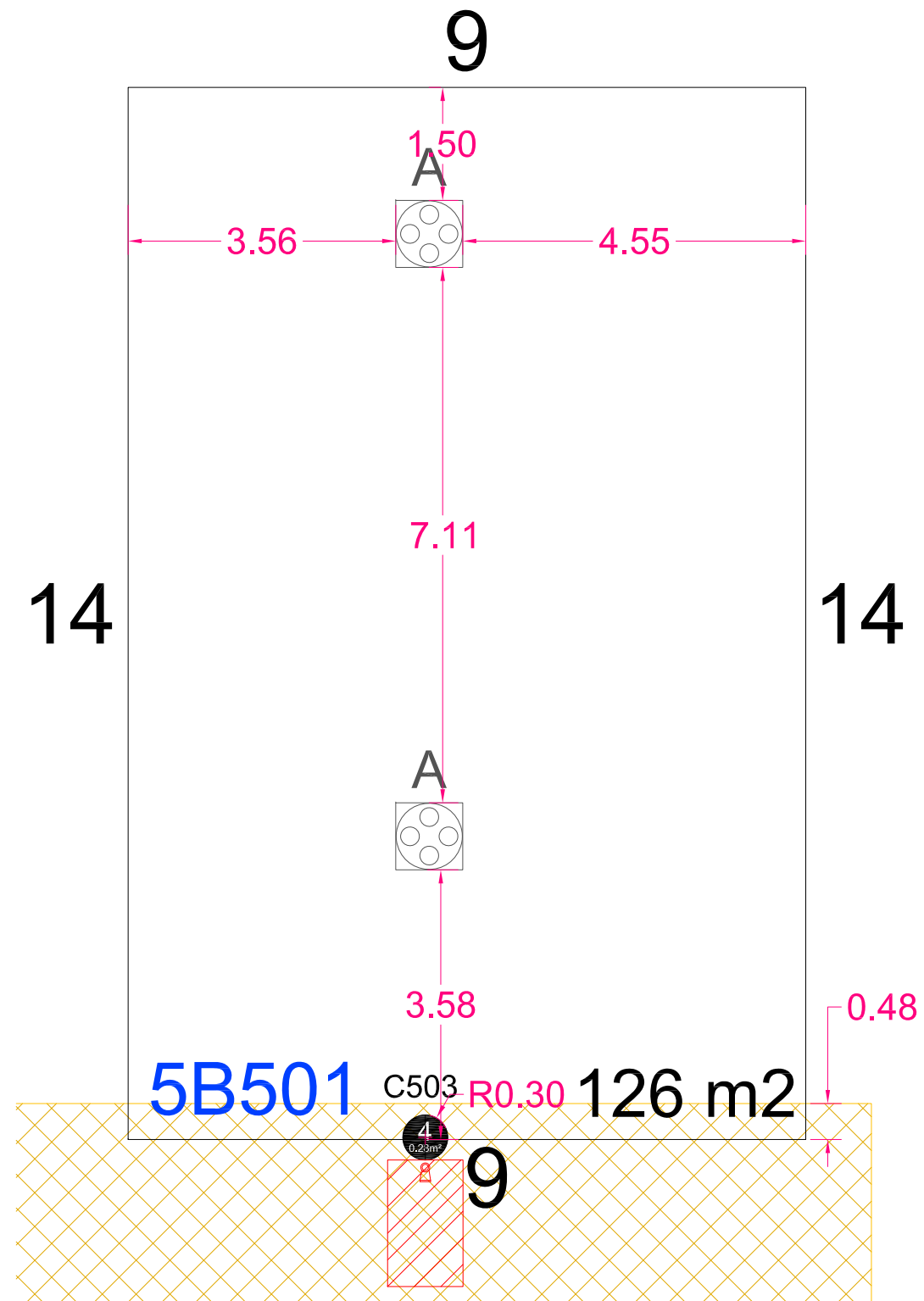

**Legend:**

- Service chest 90x90cm
- Fire hose
- Fire extinguisher

**Maximum Height**

- 6m
- 5m (Under walkway projection + 25cm)
- 4.58m
- 4.55m
- 4m
- 2.5m

**Rigging Restrictions:**

- Pre-rigging Height O-ring=7,40m

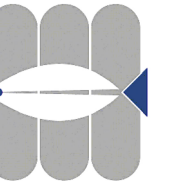

# Column details - Gran Via Hall 5

## Column type C503

### Floorplan & Dimensions

---

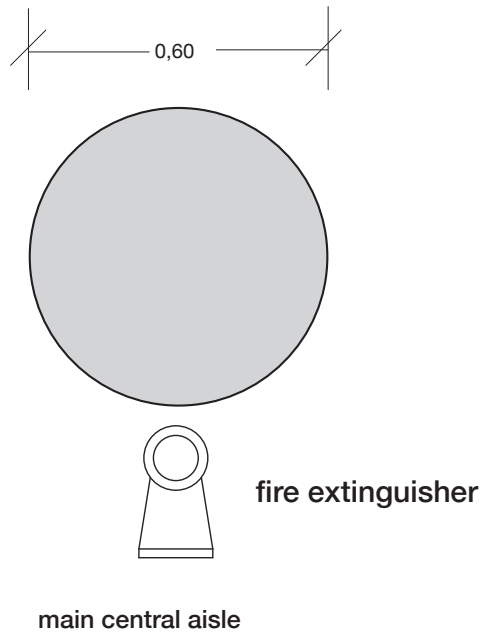

### Picture

---



# Column details - Gran Via Hall 5

## Column type C504

### Floorplan & Dimensions

---

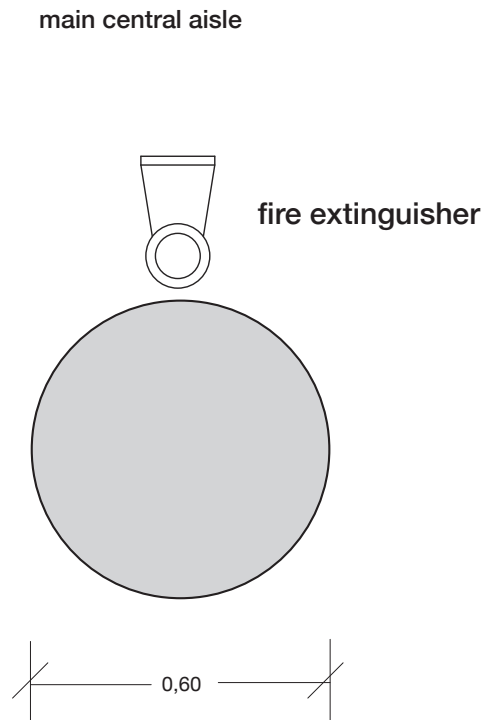

### Picture

---

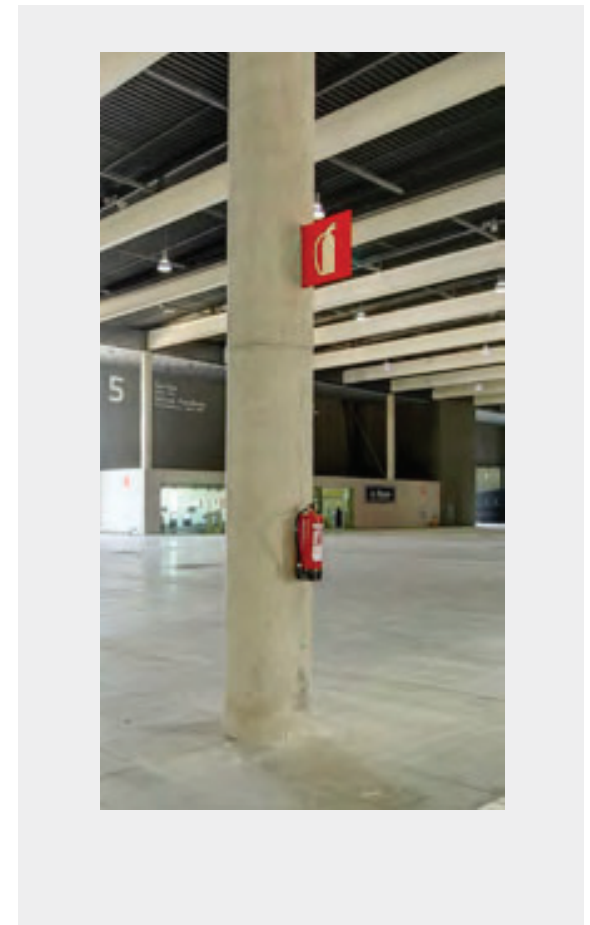

## DESIGN REGULATIONS FOR ALL STANDS

### **Covering of Columns *\*\*New in 2021***

If you have columns as part of your stand, no construction, clamps, lighting, etc, can be adhered to or onto the walls, columns or other fixed elements of the halls. In the case of cladding or decorating columns with fire equipment, extinguishers, fire alarm call points, signage or any other informational element of the venue, they must always be visible, accessible and clear of obstacles that may prevent their normal use. It is prohibited to manipulate or disassemble any of these information elements.

Hall columns inside the stand can be branded in accordance with the permitted height regulations. In the case where a column is intersected by the stand space and part of the column lies outside of the contracted space, exhibitors are permitted to brand/build a structure around the full column. Please note, you **cannot build further than 20cm from the column**.

Vinyl wraps or directive adhesive clings are permitted to be installed on the columns but only by official Fira suppliers. This service can be contracted through the sales department of [Fira Barcelona](#).

### **Cubic Content**

“Cubic content” refers to the dimensions of your rented space including walls, decorations and any other fixtures. The cubic content of your exhibit space can be fully utilized, i.e., all of the fixtures in the stand reach the maximum height of that particular stand type. **Height limits vary, depending on the stand location and size. Please refer to the following pages for regulations corresponding to your stand type.**

### **Fixed Access Ramps *\*\*New in 2021***

Per safety and accessibility regulations of the Spanish Technical Building Code, all stands with a platform at 5cm or higher are REQUIRED to build an accessibility ramp.

Stands larger than 20sqm are required to install a fixed access ramp within the confines of the stand space.

Stands 20sqm or smaller may utilize a portable ramp if space does not permit for a fixed access ramp. Servifira offers rental ramps and you can inquire by contacting them at [seafood@firabarcelona.com](mailto:seafood@firabarcelona.com).

Please note these additional regulations regarding ramps and accessibility:

- The fixed access ramp to the platform shall not exceed the limits of the area of the stand. The ramp slope cannot be above 10%.
- The height of the stand platform from the hall floor cannot be greater than 18cm.

### **Floor Covering/Platforms *\*\*NEW in 2021***

**Each exhibitor is responsible for providing fireproofed and secure floor covering.** Please note, Fira Barcelona utilizes service chests on the exhibit hall floor throughout the facility. If you are ordering electrical, water, or compressed air, you may be required to build a platform around the area of the service chest to provide access. If a service chest is shared between more than one stand, it must always remain accessible through a hatch. We recommend a platform of 5cm for electrical cables only and a 10cm if a water connection or a large amount of power is planned. More information can be found [here](#). For questions on this, please contact [seafood@firabarcelona.com](mailto:seafood@firabarcelona.com)

### **Graphics Facing Neighboring Stands**

All stands that have graphics facing directly into the neighboring stand must be placed at a minimum of 2m from the wall, and no higher than the maximum height allowed for your particular stand type.

### **Lighting/Flags/Truss**

No lighting, lighting fixtures, lighting trusses, or overhead lighting are allowed outside the boundaries of the exhibit space. Exhibitors intending to use hanging light systems must submit drawings to exposition organizers for approval. Lighting should be directed to the inner confines of the stand space. Lighting should not project onto other exhibits or exposition aisles. Flags must comply with the maximum height regulation corresponding to the stand type and displayed within the perimeter of the stand space. **The maximum height regulation per stand should be measured from the floor to top of the truss.**

### **Promotion of Other Events**

Literature, videos, or graphics promoting other events is strictly prohibited.

# DESIGN SPECIFICATIONS | HEIGHT RESTRICTIONS



## **Solid Walls**

Exhibit displays should be designed in such a way as to allow for maximized visibility to both you and those around you. **Stand sides facing an aisle must include a natural break or clear/no color plexi panel of at least 2 meters for every 4 linear meters of solid wall.** The use of shades, blinds, curtains, or any other item to otherwise block the clear glass to create a continuation of the wall is not permitted. Solid walls over 4m in length need to be located at least 2m away from the aisle. If you wish to have a wall adjacent to the aisle that exceeds 4 meters in length, the max height of the wall must be 1 meter. This rule will be strongly reinforced onsite.

## **Stand Construction Safety**

The exhibitor is responsible for the structural safety of the stand. Stand builders and exhibitors are required to adhere to all Fira Barcelona Safety Regulations, including all inspection requirements. Exhibition stands including equipment, exhibits, and advertising material must be erected in such a stable manner as to avoid endangering life and limb, as well as safety and order. All exhibit displays should be designed & erected in a manner that will withstand normal contact or vibration caused by neighboring exhibitors, hall laborers or installation/dismantling equipment such as forklifts. Displays should also be able to withstand moderate wind effects that may occur in the exhibit hall when freight doors are open. Exhibitors should ensure that any display fixtures such as tables, racks or shelves are designed and installed properly to support the product or marketing materials to be displayed upon them.

## **Preventative Measures **\*\*NEW IN 2021****

Operators working at height must be provided with sufficient safety material to prevent the risk of falling (safety harnesses, ladders, scaffolding, etc.). Welding equipment shall not be used without Fira's prior authorization. Please speak to your Hall Manager before attempting any welding on site. The maximum speed limit in the Fira Barcelona venue will be 10 kph.

The use of safety footwear, gloves protecting against mechanical hazards and protective glasses is compulsory. The use of a safety helmet will be required in work that requires it (risk of falling objects, double decker stands, blows from suspended objects, etc.). **The use of reflective or high visibility vests is mandatory.**

## **Stand Ceiling Installation**

Exhibitors may cover their stands with a ceiling, provided that they observe the technical directives on fire protection and the safety regulations. Since the ceilings can be seen from higher floors, their finish should always be aesthetically pleasing. If building a ceiling within the stand, we recommend that the ceiling be permeable so that the general temperature control of the hall reaches the space of the stand.

## **Stand Construction Authorization**

All exhibitors must submit their stand design to the event organizer (Diversified Communications) through the online [Stand Approval Form](#). Construction of the stand may only commence after approval has been granted. Should the structure be deemed a Complex Structure (see bottom section of this document), you will need to provide proof that your stand has been reviewed and approved by Servifira or your individual engineering company in order to be built onsite. See below for more information.

## **Stand Partition Wall**

Each exhibitor is responsible for erecting sidewall and back wall partitions of solid construction of 2.5m in height between their own and adjoining stands. The reverse side of the partition walls that are above 2.5m in height must be finished and painted in white color so as to not interfere with the design of the neighboring stands.

## **Stands Under the Walkway **\*\*New in 2021****

Stands that have part of their space located under the walkway will have a variance in their maximum height (5m or 6m) and they must leave a 1 meter gap in between any structure/trussing and the walkway to allow space to finish that area.

## **Use of Area Outside of Purchased Stand Space is Prohibited**

Storage behind stands or use of any area outside of paid stand space is strictly prohibited. Areas behind stands should be kept clear of debris, tools, equipment, products, or any other materials. Action will be taken by the Event Organizer to remove any stored items at the expense of the stand builder or exhibitor. Fine may apply.



## COMPLEX STRUCTURES \*\*NEW IN 2021

A complex structure is regarded as any construction which, due to Spanish Technical Building Code, requires the intervention of a competent technician related to the design, calculation or certification of its final strength or if the assessment of a significant risk is required.

Stand Designs that qualify as a “Complex Structures” are classified as follows:

- Double Decker/Two storey stand accessible to people on both floors.
- Stand Constructions that exceed 5 meters in height. (does not include the truss, banner, etc.)
- Platforms or stages equal to or greater than 50cm high.
- Single structures that are greater than 4 meters high.

Please note that if your stand has hanging structures and/or trussing but does not have any of the classifications explained above, they the stand is not considered a complex structure.

Complex structures must comply with the requirements set forth in the current regulations and, specifically, in the contents of all sections of the Spanish Technical Building Code, as well as the basic documents of structural safety (BD SS), fire safety (BD FS) and safe use and accessibility (BD SUA). Authorization to construct any of these structures must be requested providing the following documentation:

**Pre-Show:** Project approval stamped by the corresponding professional association, which includes:

- A descriptive and explanatory report of compliance with the current regulations.
- A structural study with static calculation, which includes the verification of each element of the structure and the description of loads transferred to the pavement under each support.
- A floorplan and elevation drawings, including details of the handrails and stairs.
- The evacuation and fire detection plan for structures with a surface larger than 100 m<sup>2</sup>.
- Assessment of risks and preventive measures to consider during the construction build up and break down process.
- In the case of a structure homologated by a qualified and authorized organism, the approval homologation certificate of the structure, along with the build-up and break down regulations shall be submitted to replace the structural study.

In the case of double deckers/two storeys, it will also be required to provide a technical responsibility letter including the stamp and endorsement by the corresponding professional college and signed by a competent technician. This document must be provided before the beginning of the build-up period.

**On-site:** Once the construction of the complex structure is complete, the responsible technician shall issue the corresponding final certificate of solidity approved and stamped by the corresponding professional association.

**Approval Process:** once the stand design has been submitted to the expo organizer through our [Online Stand Approval form](#), if the stand is deemed a complex structure the design must also be sent to the Fira Complex Structure Engineer or to the Catalonia Technical Engineers Professional Association for review.

Servifira, the official general contractor for Seafood Expo Global and Seafood Processing Global, offers this technical service for pre-show and on-site review and approval through their technical department. However, exhibitors and stand builders do have the option to utilize their own Catalonia Technical Engineer for approval if they prefer.

If you chose Servifira for the service, their flat fee will be 390€.

During the engineering review, if there are any objections or amendments needed to the design the exhibitor will work with the corresponding engineer until all the amendments have been made to the design for approval. Should any changes be required by the engineer, the exhibitor/stand builder must relay these adjustments to the organizer, so the stand design reflects all updates.

## STANDS OPEN ON 1 OR 2 SIDES | INLINE STANDS

Inline stands have only one or two sides open to an aisle and are generally in a series along a straight line.

### **Inline stands smaller than 6m wide x 6m deep**

These stands may build up to 2.75m from the exhibit floor, including the platform.

If the sidewalls and back wall of your stand are up to 2.75m in height, please make sure the reverse side of the walls above a height of 2.5m is finished in white color so as to not interfere with the designs of the neighboring stand.

Please note: hanging signs are not permitted in inline stands smaller than 6m wide x 6m deep.

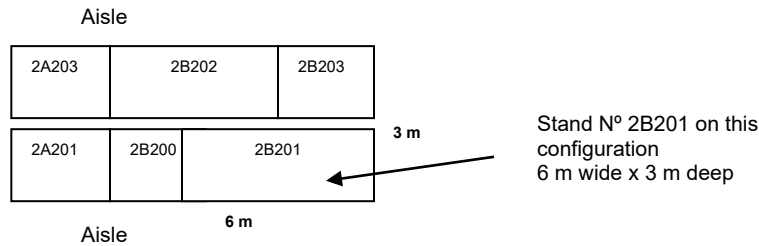

### **Inline stands with minimum dimensions of 6m wide x 6m deep**

These stands may build up to 6m high from the exhibit floor, including the platform. Please note: this does not mean that all stands that are at least 36 square meters may build up to 6m. Stands must be at least 6m wide x 6m deep to be able to be built up to 6m.

The back wall or sidewall adjacent to neighboring stands may only contain graphics that have lettering on one side – the side that is facing into your own stand. Signs facing directly into the neighboring stand must be placed at a minimum of 2m from the wall, and no higher than the maximum height allowed for your particular stand type. The maximum height should be measured from the floor to the top of truss.

Please make sure the reverse side of the dividing walls above a height of 2.5m is finished in white color so as to not interfere with the designs of the neighboring stand.

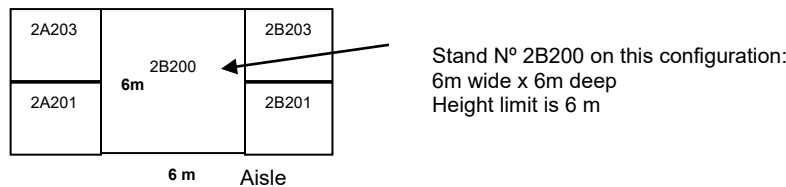

## STANDS OPEN ON 3 SIDES | PENINSULA STANDS

Stands open to aisles on 3 sides may build up to 6 meters high, including the platform to the top of the truss.

The backwall adjacent to the neighboring stand may only contain graphics that have lettering on one side – the side that is facing into your stand. Signs facing directly into the neighboring stand must be placed at a minimum of 2m from the wall, and no higher than the maximum height allowed for your particular stand type.

Be sure the reverse side of your backwall that is above a height of 2.5m is finished in white color so as to not interfere with the designs of the neighboring stand.

## STANDS OPEN ON 4 SIDES | ISLAND STANDS

Stands open to aisles on 4 sides may build up to 6 meters high including the platform where ceiling heights allows. The maximum height should be measured from the floor to the top of truss.

**Hall 2, Hall 3 & Patio:** Certain stands in the Patio and along the walkway may have some height restrictions.

## STANDS AGAINST THE EXTERIOR WALLS | PERIMETER STANDS

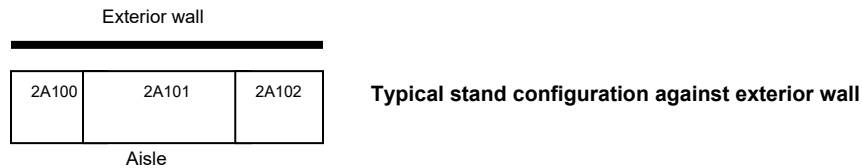

Perimeter stands may be built up to 6m high where ceiling heights allow. Please note that some perimeter stands will need to have their full backwall finished and in white color as it may be facing public areas.

Due to building obstructions, stands in the following Halls may NOT be able to build up to 6m:

**Hall 2:** The maximum height along the perimeter varies from 4m to 6m.

The backwall or sidewall adjacent to neighboring stands may only contain graphics that have lettering on one side – the side that is facing into your own stand. Signs facing directly into the neighboring stand must be placed at a minimum of 2m from the wall, and no higher than the maximum height allowed for your particular stand type. The maximum height should be measured from the floor to the top of truss.

Please make sure the reverse side of the dividing walls above a height of 2.5m is finished in white color so as to not interfere with the designs of the neighboring stand.

Storage behind stands or use of any area outside of paid stand space is strictly prohibited. Areas behind stands should be kept clear of debris, tools, equipment, products or any other materials. Action will be taken by the Event Organizer to remove any stored items at the expense of the stand builder or exhibitor. **Fine may apply.**